

# A REVIEW ON SUPERSONIC MIXING ENHANCEMENT CONCEPTS

Geva Nagar

Research project under supervision of Dr. Dan Michaels

## **Abstract**

At present, one of the critical issues related to design of scramjet engine is to achieve efficient mixing between the air and fuel. The very short residence time of the air inside the combustor intensifies the importance of the mixing process. However, usually it is quite difficult to mix fuel with air in very short distance. In this review we will present variety of concepts investigated by researchers over the years in the field of fuel and air mixing in the scramjet.

## **Introduction**

The supersonic combustion ramjet aka scramjet may be one of the most promising engine cycles in the near future due to its ability to work efficiently at hypersonic velocities. The hypersonic airflow enters the engine passes through the intake and the diffuser before it arrives to the combustor segment at Mach larger than 1. The supersonic Mach number of the free stream in this region sets a very short residence time of the flow inside of the combustor. The flowfield in a combustor of such an engine is complex and presents a challenge in achieving an efficient combustion and promise the use of the whole fuel injected into the airflow. Therefore, the main challenge of the injection system is mixing the fuel and air, creating a mixture that will have an efficient combustion downstream. The field of fuel and air mixing in the scramjet was investigated by considerable number of researches throughout the years and many mixing enhancement techniques were developed. The different mixing enhancement concepts can be classified as concepts that use passive mixing devices and concepts use active mixing devices.

The passive approach rely on geometrical changes in the combustor such as creating backward steps or cavities, immersing obstacles that can shed vortices inside the, leads to improvement in the mixing between fuel and air. In this paper we will present different passive mixing concepts which investigated by researchers for the last few years.

## 1. Ramps

Planting an obstacle with a shape of an inclined ramp that can generate vortices, is one of the most common ideas in the mixing field. Usually, the ramp is placed at the bottom of the combustor, as we can see in Fig. 1 from the work of Li et al. [1]

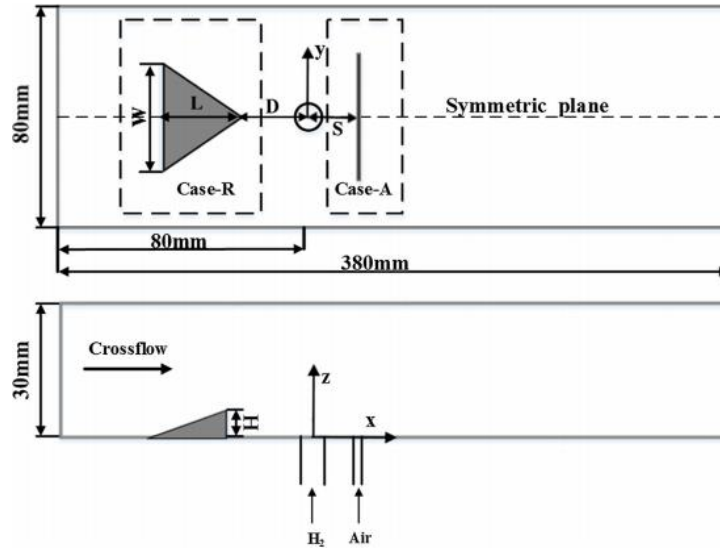

Figure 1: Plan and symmetric views of transverse gaseous injection cases.

The flow over the ramp induces a pair of counter-rotating streamwise vortices as can be seen in Fig. 2 [2]. The use of the streamwise vortices is one of the promising ideas for enhancement of fuel/air mixing in supersonic flow.

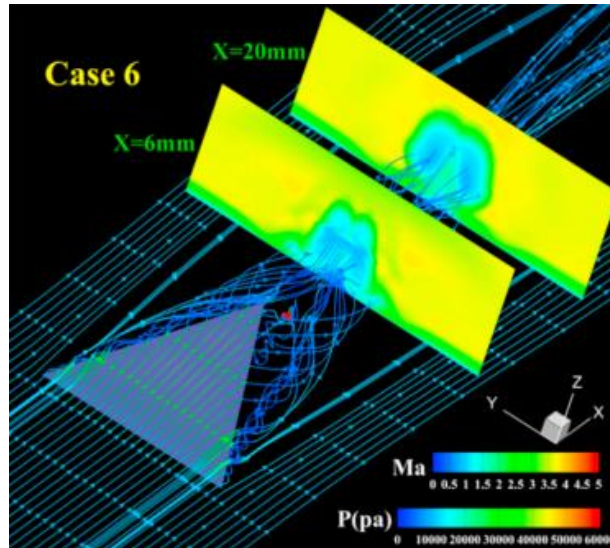

Figure 2: Streamline distribution over ramp and parametric contours on two cross-sectional planes.

The use of inclined ramps is very wide and throughout the years a lot of variations of it were developed. For example, in Fig. 3 [3] we can a concept involving fuel injection in the streamwise direction and inclined ramps.

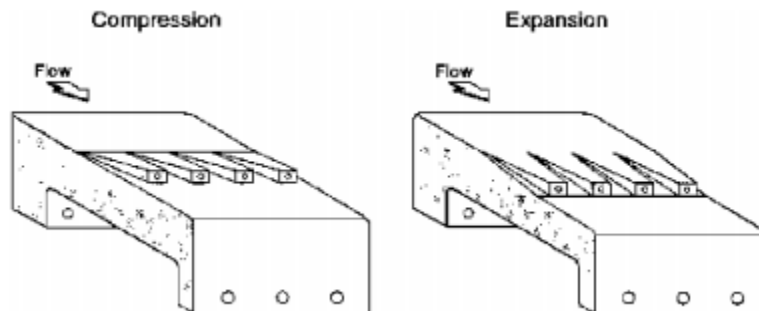

Figure 3: Scramjet fuel injector compression and expansion ramps.

### swept ramps

Another development in the ramp field done to improve the performance of the standard ramp was cutting the side edges with different angles and creating a new type of ramp configuration called swept ramps. In the research of Huang et al. [4], three cantilevered ramp injectors were considered with different swept angles (5, 10, 15) [deg], while the ramp angle (5[deg]) and the step length (9.75[mm]) kept constant. The influences of the swept angle on the flow field of the cantilevered ramp injector were investigated numerically and shown in Fig. 4.

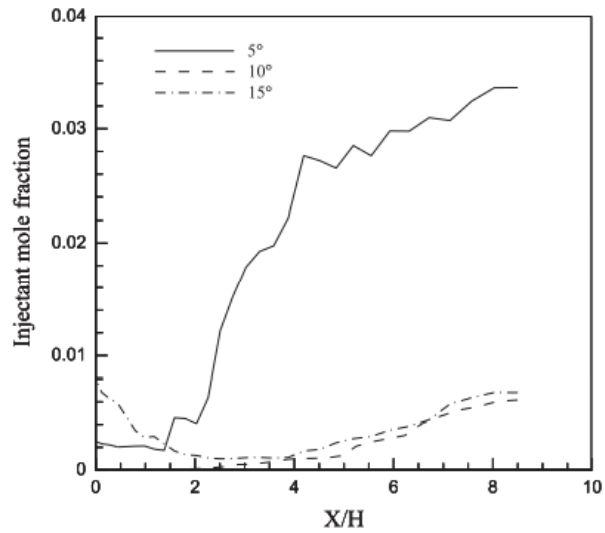

Figure 4: Comparison of the axial distributions of the maximum injectant mole fraction with different swept angles.

In the plot we can see the axial distributions of the maximum injectant mole fraction versus the X coordinate normalized by the height of the ramp. It is observed that the injectant mole fraction

increases with the axial distance except the configuration of 15[deg] swept angle. In addition, Huang et al. found that the axial distribution of the injectant mole fraction is the lowest when the swept angle is 10[deg], and therefore suggested that there may be an optimal value exist for the swept angle of the cantilevered ramp injector in the supersonic flow. In Fig. 5, we can see slices of the injectant mole fraction at three cross-sectional planes for the three different swept angles. The larger swept angle significantly increases the overall spread and mixing of the injectant. This is due to the vortices generated by the pressure gradient between the ramp top surface and the ramp sides which enhanced with the rise of the swept angle. Kubo et al. [5] also investigated experimentally the effect of applying a sweep angle to strut injectors. In Fig. 6 we can see the swept version and the unswept version of the strut type ramp injector they tested.

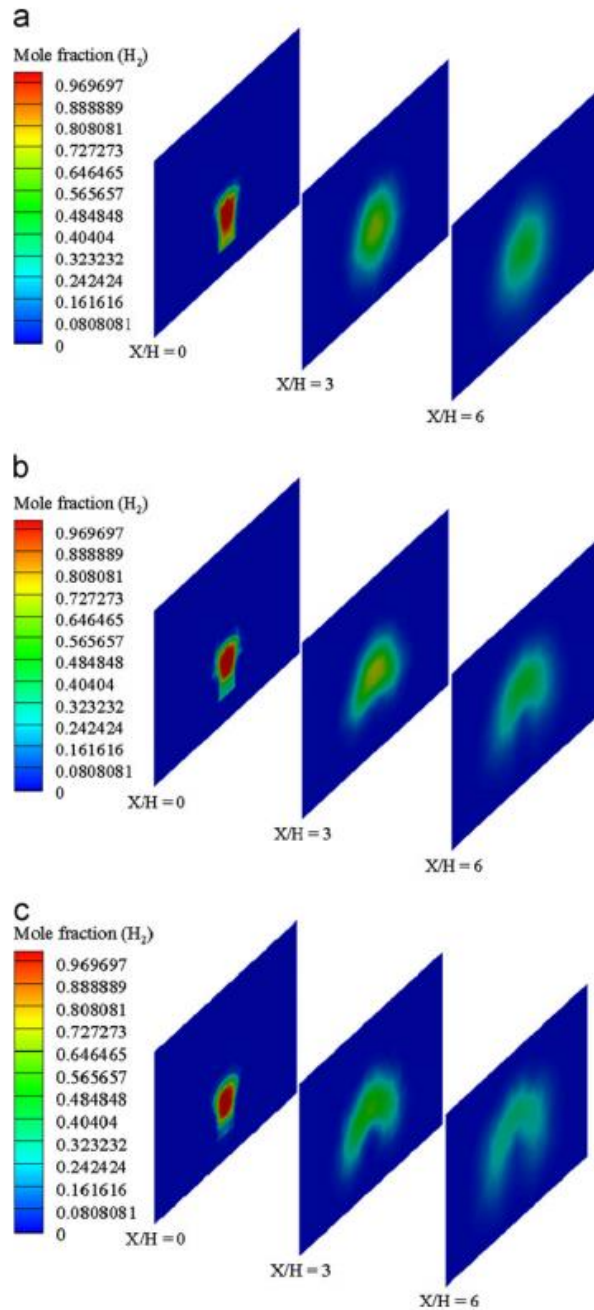

Figure 5: Slices of the injectant mole fraction at three cross-sectional planes.

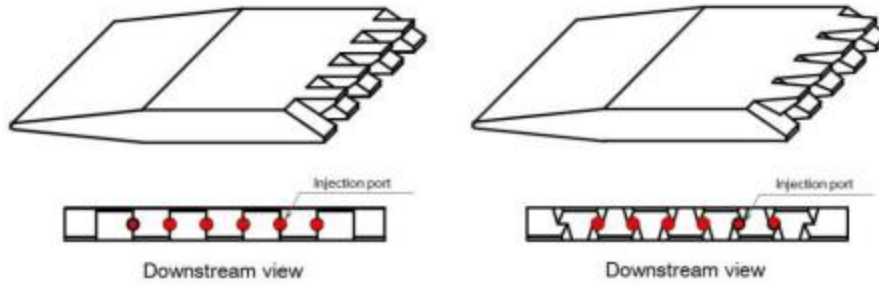

Figure 6: 2 The schematic of strut type ramp injector. (left) unswept version, (right) swept version.

Their experiments results indicated that when streamwise vortices were not introduced well due to inadequate ramp angle, injectors with swept ramps showed a higher thrust performance than that with non-swept ramps. This phenomenon can be showed in Fig. 7 where there is a major improvement between the swept and unswept ramp version at the larger ramp angle with 36[deg] while only a slight improvement in the 22[deg] ramp angle.

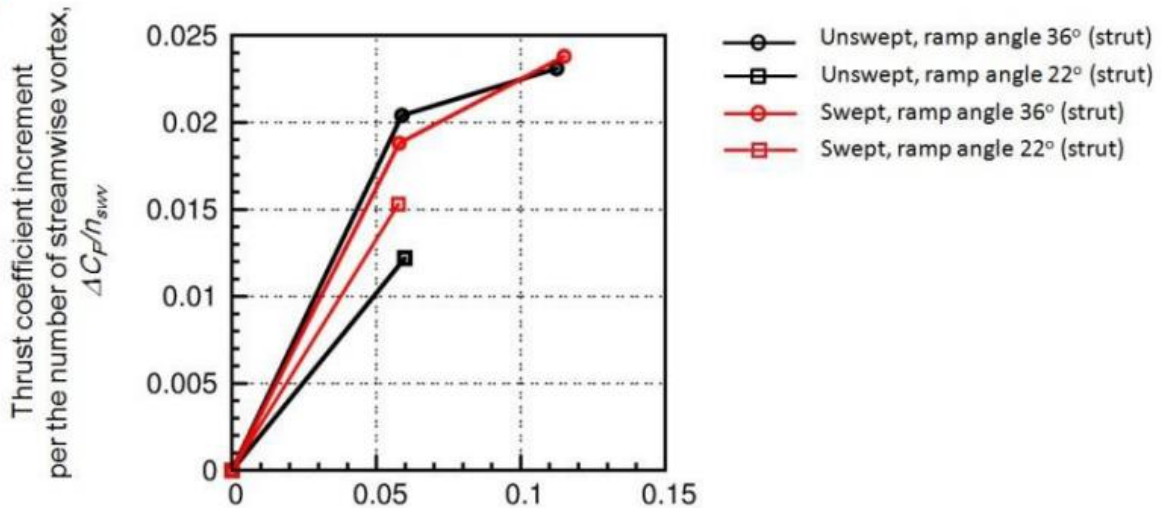

Figure 7: Comparison between the thrust coefficient increment of swept and unswept ramp.

### Micro-ramps

Zhang et al. [6] conducted a numerical research using LES simulations in order to investigate the effect of micro-ramps on transverse fuel injectors mixing efficiency and penetration into supersonic crossflow. They used a ramp which can fit fully inside the boundary layer and produces counter vortices pairs in the near-wall region up washing the low energy part of boundary layer into the main flow, because of the ramp's size the total pressure loss is obviously small. The micro-ramp configuration and its placement are shown in Fig. 8.

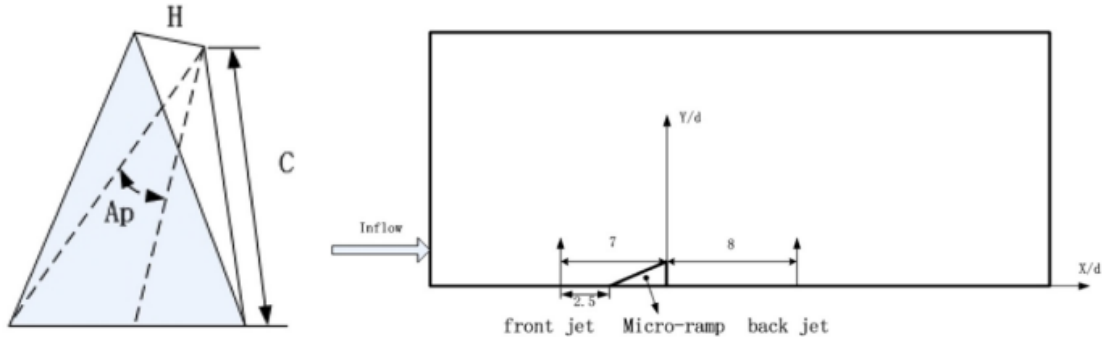

Figure 8: Configuration of the micro-ramp (left). The simulated model where  $X$  is the flow Direction and  $Y$  is the tunnel's height, micro-ramp and jet orifices at the tunnels floor (right)

Previous studies showed that the penetration height of the fuel into the supersonic flow is proportional to the ratio of the jet orifice momentum flux to crossflow momentum flux in the injection region, as shown in Eq 1.

$$J = \frac{\rho_j \cdot v_j^2}{\rho \cdot u^2} \quad (1)$$

Zhang et al. found out that the presence of micro-ramp decreasing the flow momentum flux after the micro-ramp location, as shown in Fig. 9. Therefore, fuel injection in this particular area has a positive effect in a sense of fuel penetration and mixing efficiency improvement.

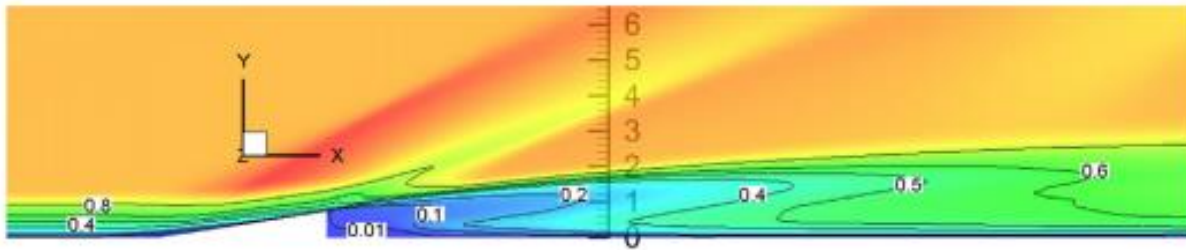
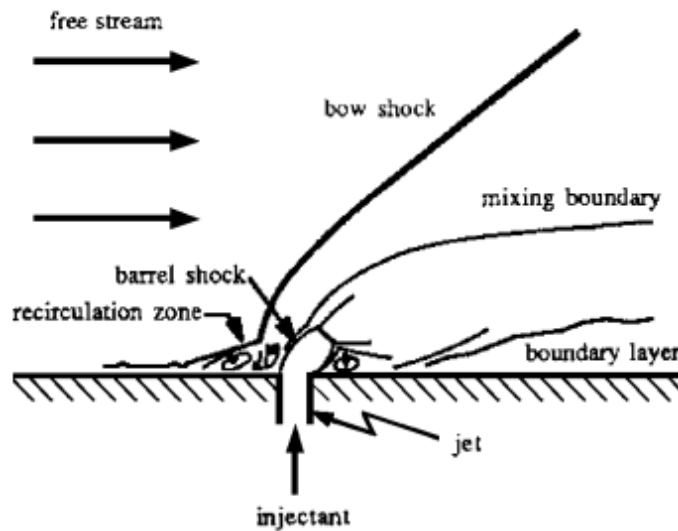

Figure 9: Contours of the flow momentum flux (black lines) inside the boundary layer from LES simulation.

## 2. Fuel Injection Methods

The method that is used to inject the liquid fuel into the supersonic airflow has a major effect on the mixing process between the two. Due to its simplest and most conventional design, the transverse fuel jet is the main method applied in scramjet. The injected plume generates a bow shock that interacts with the incoming airflow, a turbulent shear layer and a system of flow structures are formed, as shown in Fig. 10 [3]. The jet is turned downstream, and the vortices' rotation axes align nearly with the airstream, facilitating jet-air mixing.



*Figure 10: Normal fuel injection.*

### Various injection angles

In order to develop the supersonic mixing, it is very important to understand the effect of injection angle. Aso et al. [7] investigated the effect of injection angle with circular sonic nozzle by changing the injection angle. They conducted experimental and computational studies on supersonic mixing phenomena of two-dimensional slot injector with three different injection angles (30,90,150) [deg]. In Fig. 11 lower side, we can see the flat plate model visualized by the oil flow technique while the upper side shows the streamline from calculation result. The two pictures' halves fitting each other, indicates that the numerical results show good agreement with their experimental results.



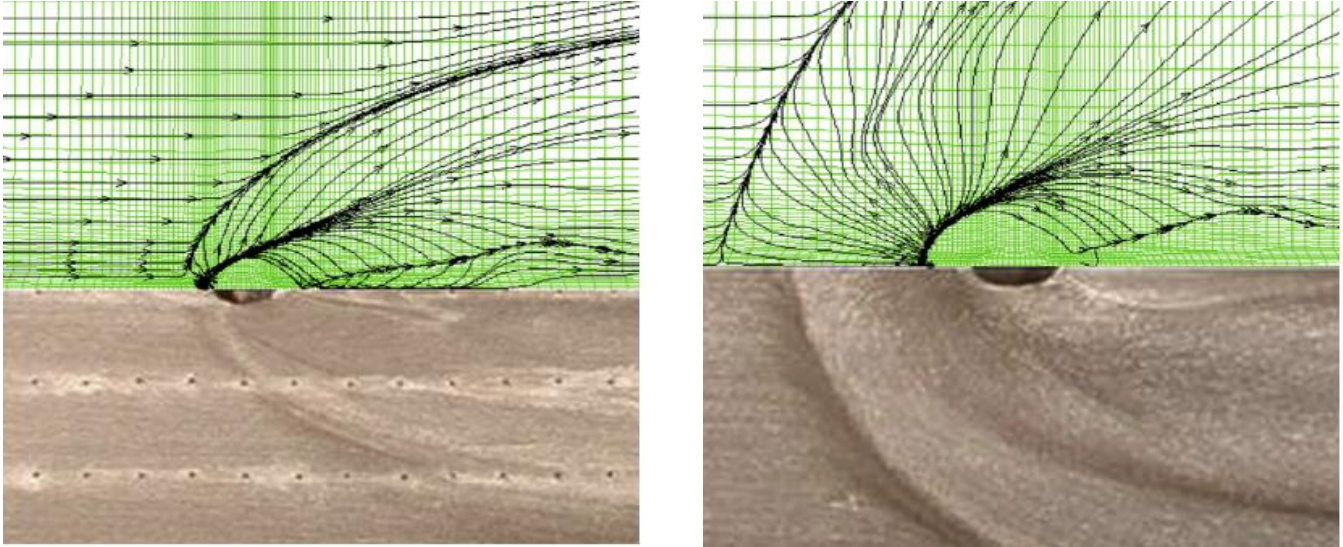

Figure 11: (Lower side) Oil flow picture, (Upper side) Stream line from calculation result

As expected, the case where fuel injected in an angle of 30[deg] to the free stream yielding a relative weak interaction between the fluids, creating only a single separation line. On the other hand, the interaction of airflow/fuel where fuel injected against the free stream, in an angle of 150[deg] causing a primary separation line and a secondary separation line. Also, oil flow pictures show a reattachment line and flow toward centerline generated by longitudinal vortices at inside of the primary separation line. Aso et al. defined mixing efficiency as the ratio of the mass flow rate of hydrogen to that of the combustible one at local plane, as can be seen in Eq. 2.

$$\eta(x) = \frac{\int_A \frac{\rho u f_{H_2}}{\Phi} dA}{\int_A \rho u f_{H_2} dA} \quad (2)$$

In Fig. 12, they present the history of mixing efficiency, calculated at each section of the tunnel using Eq.2. Mixing efficiency grows rapidly near the nozzle in 90[deg] and 30[deg] cases, where injected gas is captured into the longitudinal vortices.

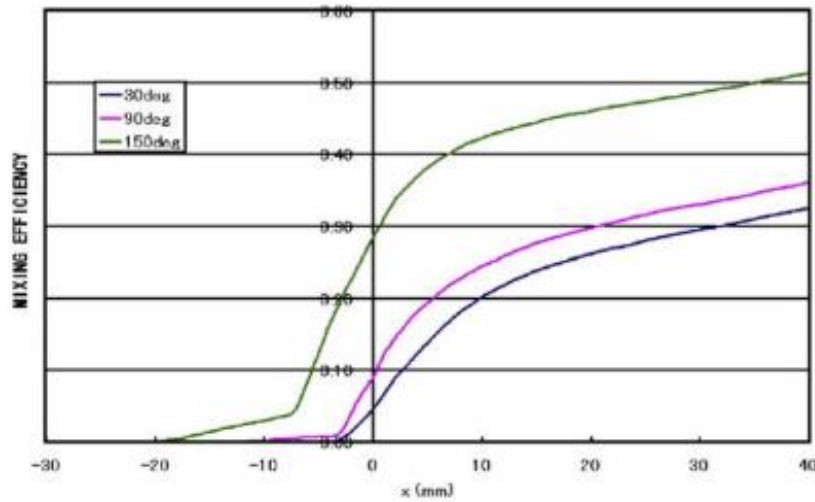

Figure 12: Mixing efficiency along with flow direction

After this process, no large difference of increasing rate of mixing efficiency among three cases is obtained. It is considered that the injection angle has little effect on mixing efficiency, after injected gas captured into the longitudinal vortices. In the study conducted by Zhang et al. [8], the flow structures and their contribution to the mixing process, created by fuel injection in a 45[deg] jet are compared to those created by injection in 90[deg]. Their simulation results are observed that the penetration height of 90[deg] jet is higher than 45[deg] jet, as shown in Fig. 13. Considering Eq. 1 and the fact that 90[deg] jet has transverse velocity that is  $\sqrt{2}$  times larger than in 45 [deg]. We understand that the J of 90[deg] jet is 2 times larger than that of 45[deg] jet, which results in the higher penetration height in former case.

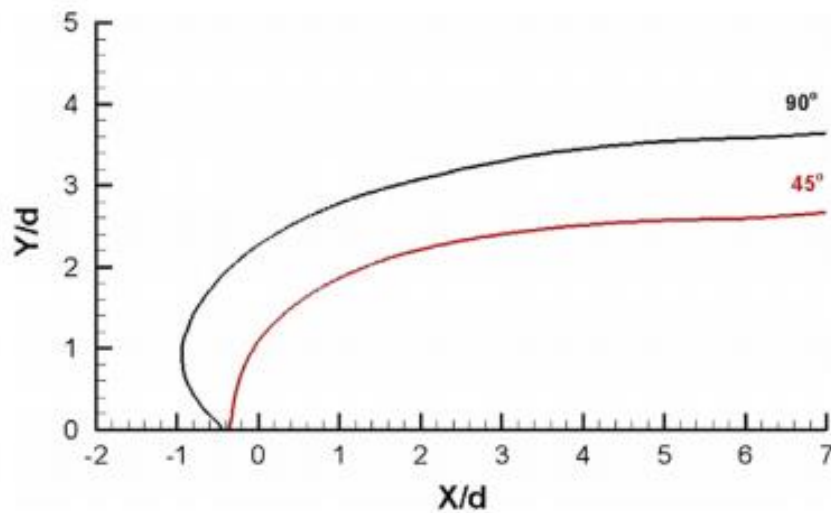

Figure 13: Penetration height comparison

Zhang et al. also calculated the mixing efficiency for the two fuel injection methods, as shown in Fig. 14. It is observed that the mixing efficiency of 90[deg] jet is higher than that of 45[deg] jet. Based on the on the penetration height comparison and the strong relation between penetration and mixing this result can be expected.

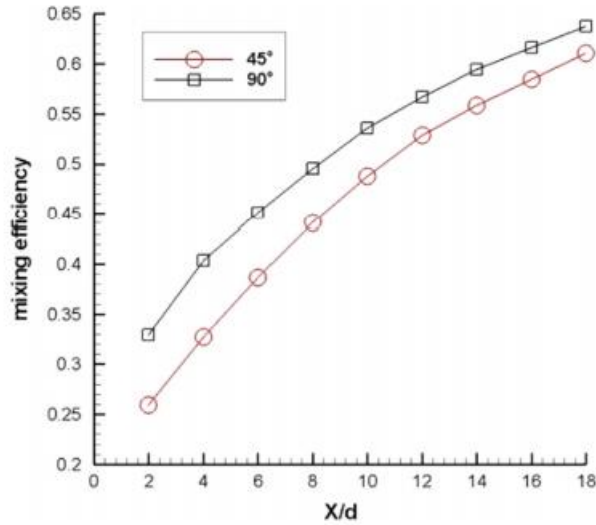

Figure 14: Mixing efficiency comparison

### multiple injections

The flow field of a multiple transverse injection system in a supersonic airflow is even more complex than that of a single transverse injection system due to the interactions among the injection flows. Complications of an efficient injection system setup also arise due to many other parameters, including positioning of each injector, injection angle, and combination of injection angles.

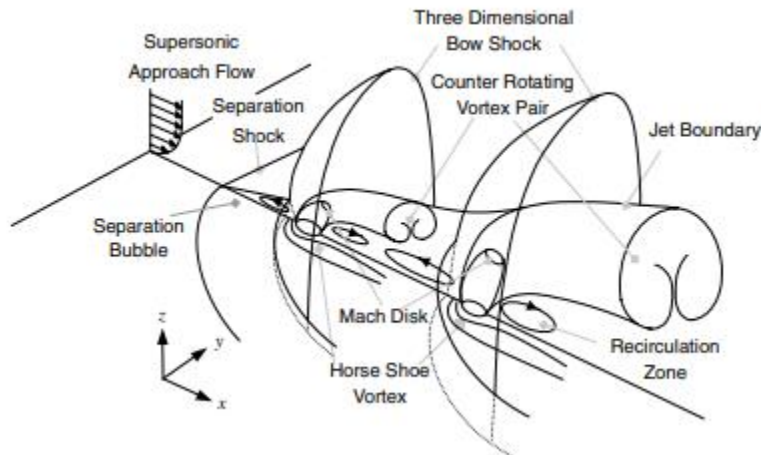

Figure 15: Schematic view of mean flowfield of dual transverse injection

In the study of Lee [9], the objective was to analyze the interactions between jet flows and to investigate the influences of these interactions on the mixing characteristics of a dual transverse injection system. Lee chose to use a dual transverse injection system as a basic model for multiple transverse injection systems in which the injectors are located in a line, as shown in Fig. 15. Lee found out that the rear injection flow in a dual injection system is strongly influenced by the front injection flow. The rear injection flow has a higher expansion than the front injection flow due to the blockage effects, which resulted in better mixing and higher penetrations of fuel jet into the airflow. It was also found that the mixing efficiencies and penetrations increased as the distance between injectors increased until a critical distance but then decreased after that critical distance. As can be seen in Fig. 16, the decay rate of maximum mass-fraction of injectant is increased with the distance between injectors until a certain distance. As seen on the plot, we the cases of D3 and D4 are decaying faster than D1 but D7 is not.

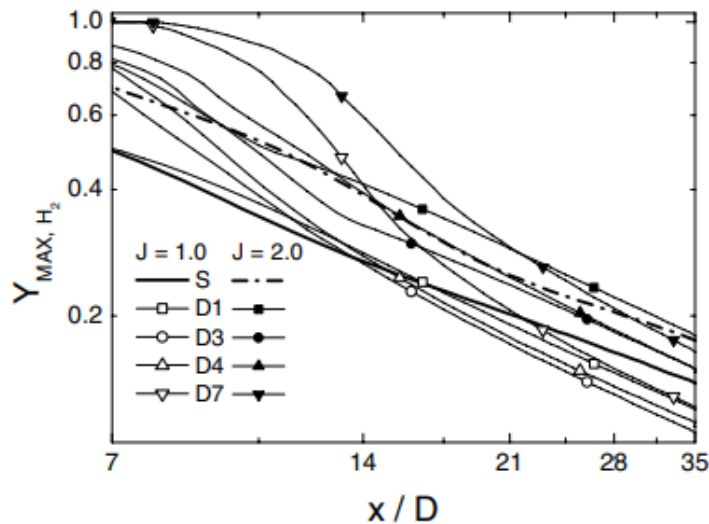

Figure 16: Comparison of mixing rate expressed by decay rate of maximum mass-fraction of injectant

In addition, Lee found that the increased losses of stagnation pressure of dual injection systems are not so great considering the mixing enhancement with respect to that of the single injection system. In the study conducted by Peng et al. [10] the multi jet injection investigated with combination of upstream step geometry, as shown in Fig. 17.

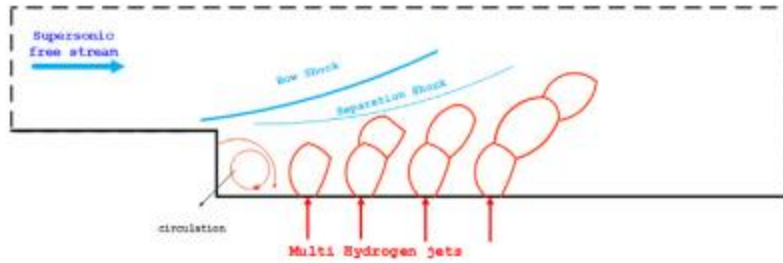

Figure 17: Geometry of Peng et al. simulation.

According to Fig. 18, increasing the jet spaces decreases the local fuel mixing in the neighborhood of the initial jet while the mixing fuel augments in the downstream. Their results show that vortices are limited and the strength of the vortices in the gap of the multi jets is low when the jet space is small. They found that as jet space enlarges, the fuel could efficiently diffuse in the spanwise direction with strength of the large vortices and jet swirl structure extended downstream. Thus, fuel mixing improves in the far downstream with raising the fuel jet space.

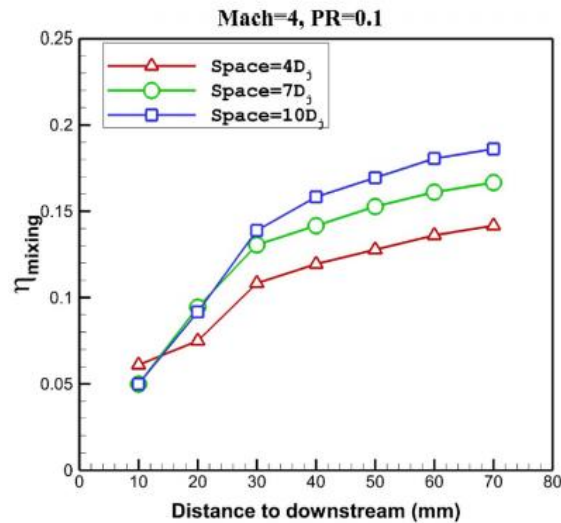

Figure 18: Impact of the fuel jet space on fuel mixing

### 3. Fuel injection within a cavity

Cavity flame holder is known as an efficient technique for providing the ignition zone. In the research of Moradi et al. [11], computational fluid dynamic is applied to study the influence of the various shapes of cavity such as circle, rectangular and trapezoidal cavities flame holders on the mixing efficiency inside the scramjet. In Fig. 19, we can see the distribution of hydrogen gas within the circle cavity with different pressure ratios. As the pressure ratio of the fuel jet increases, the interaction of the jet with the mainstream increases and the gradient of the hydrogen percentage inside/outside the cavity varies.

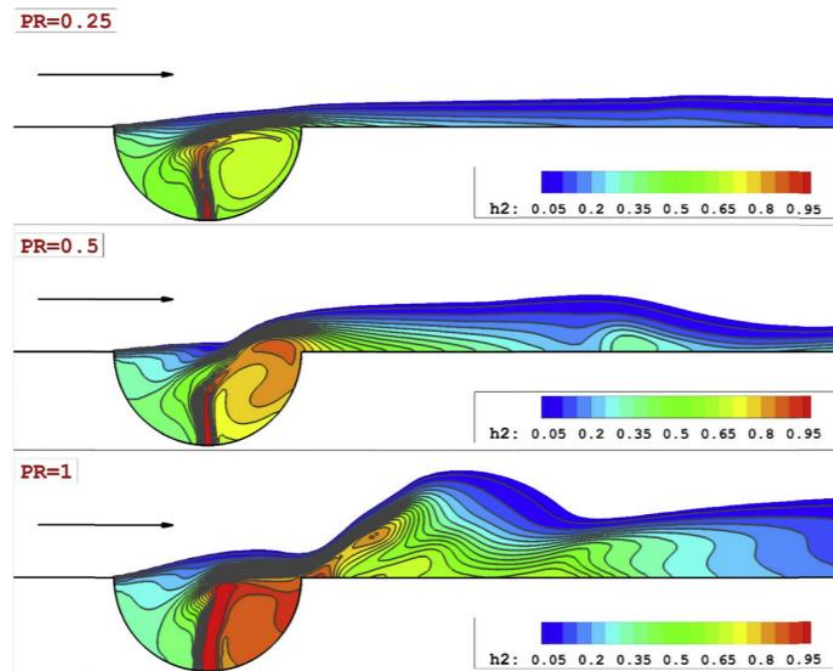

Figure 19: Effect of various pressure ratio of hydrogen jet on hydrogen mixing rate inside the circle cavity

The connection between cavity uses and mixing enhancement was also investigated by Quick et al. [12]. Their primary goal of the experiment was to characterize the mixing effectiveness of an upstream cavity coupled with fuel injected at different locations inside the cavity.

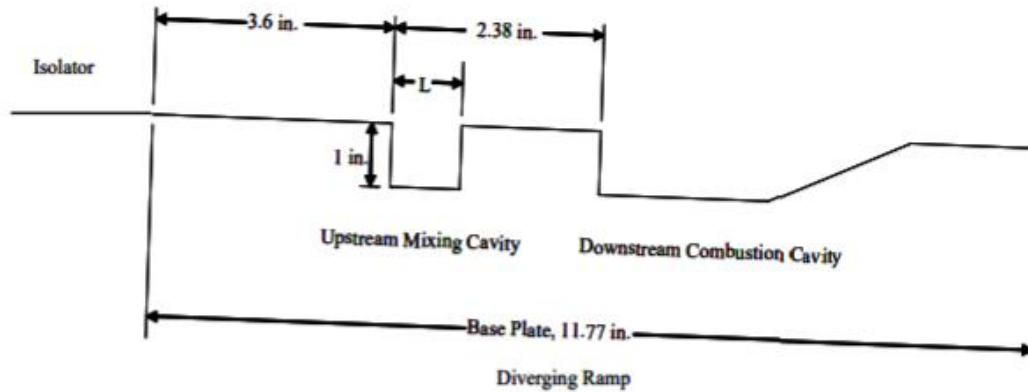

Figure 20: Divergent ramp schematic

The results of this investigation showed that the inclusion of an upstream mixing cavity can be used to control the behavior of the injectant interaction with the freestream flow. This may lead to the reduction of injection locations necessary to create efficient combustion in the engine. For instance, the lateral spreading of the injectant from a single injection point on the streamwise centerline of the cavity may be used to mix fuel with the entire span of the combustion chamber.

## Summary

In this survey, we reviewed different mixing enhancement concepts which relied on geometrical changes in the combustor such as obstacles placements and variety of fuel injection approaches. Some of the concepts used ramps at the bottom of the combustor which created streamwise vortices and allowed the fuel to spread inside the combustor. Other concepts effected the mixing process through the orientation of the fuel injectors. The different injection schemes improved the penetration height of the fuel into the supersonic flow and enhanced the mixing process as well. It also important to note that each mixing approach increases the drag inside the combustor. Therefore, there is a tradeoff between the desired efficient mixing process and stagnation pressure losses which are caused in the same process.



## **References**

- [1] L. Li, W. Huang, M. Fang, Y. Shi, Z. Li, A. Peng, Investigation on three mixing enhancement strategies in transverse gaseous injection flow fields: A numerical study, *International Journal of Heat and Mass Transfer* 132 (2019) 484-497.
- [2] W. Huang, Mixing enhancement strategies and their mechanisms in supersonic flows: A brief review, *Acta Astronautica* 145 (2018) 492-500.
- [3] J. Seiner, S. M. Dash, D. C. Kenzakowski, Historical Survey on Enhanced Mixing in Scramjet Engines, *JOURNAL OF PROPULSION AND POWER* 17 (6) (2001).
- [4] W. Huang, S. Li, L. Yan, Z. Wang, Performance evaluation and parametric analysis on cantilevered ramp injector in supersonic flows, *Acta Astronautica* 84 (2013) 141-152.
- [5] N. Kubo, A. Murakami, K. Kudo, S. Tomioka, Effects of the 'Swept' Applied to Hypermixer Injector Ramps, *Procedia Engineering* 99 (2015) 954 – 960.
- [6] Y. Zhang, W. Liu, B. Wang, M. Sun, Effects of micro-ramp on transverse jet in supersonic crossflow, *Acta Astronautica* 127 (2016) 160 – 170.
- [7] S. Aso, K. Inoue, K. Yamaguchi, Y. Tani, A study on supersonic mixing by circular nozzle with various injection angles for air breathing engine, *Acta Astronautica* 65 (2009) 687 – 695.
- [8] Y. Zhang, W. Liu, B. Wang, Effects of oblique and transverse injection on the characteristics of jet in supersonic crossflow, *Acta Astronautica* 115 (2015) 356 – 366.
- [9] S. Lee, Characteristics of Dual Transverse Injection in Scramjet Combustor, Part 1: Mixing, *JOURNAL OF PROPULSION AND POWER* 22 (5) (2006).



[10] Y. Peng, M.B. Gerdroodbary, M. Sheikholeslami, A. Shafee, H. Babazadeh, R. Moradi, Mixing enhancement of the multi hydrogen fuel jets by the backward step, *Energy* 203 (2020) 117859.

[11] R. Moradi, A. Mahyari, M.B. Gerdroodbary, A. Abdollahi, Y. Amini, Shape effect of cavity flameholder on mixing zone of hydrogen jet at supersonic flow, *International Journal of Hydrogen Energy* 43 (2018) 16364-16372.

[12] A. Quick, P.I. King, M.R. Gruber, C.D. Carter, K. Hsu, Upstream Mixing Cavity Coupled with a Downstream Flameholding Cavity Behavior in Supersonic Flow, AIAA 2005-3709.